

# DT-125-2C

ECONOMICAL 1 TO 2 COLOR PAD PRINTING MACHINE



DT-125-2C-PS  
2 color model with  
part shuttle shown

- Simple to operate using touch panel
- Microprocessor controlled
- SMC pneumatics
- Easily accessible pad stroke adjustments
- 2 position pneumatic part shuttle
- Pad blower for 2 color pad printing
- X/Y/R/Z work table
- Dual X/Y/R cliché adjustments
- Smooth & quiet machine performance

# DT-125-2C

## ECONOMICAL 1 TO 2 COLOR PAD PRINTING MACHINE

The **DT-125-2C** pad printing machine is a compact and economical one or two color pad printing system that is both user-friendly and quick to setup. It features a membrane control panel on the front faceplate and the easily accessible pad stroke controls are on the right side of the machine with numerical calibration. The **DT-125-2C** pad printer comes with a solid built welded steel machine base and it has adjustable floor levelers and a height adjustable work table. Inside the machine base you have room to store your pad printing supply items like; inks, thinners, ink cups, mixing cups, stir sticks, etc. This **DT-125-2C** is equipped with two ink cups (see specs below for sizes) and two X/Y/R adjustable cliché holders for precise alignment of two color artworks. The clichés can be; photo polymer, thin steel or laser etched varieties and **DECO TECH** provides a full array of consumable supplies, technical support & product training for our **DT SERIES** of pad printing machinery. This **DECO TECH** pad printing machine is backed with a one year warranty against defects in manufacturing.

### MACHINE SPECS

<b>Printing capacity:</b>	Up to 1,800/hr (1 color) Up to 1,200/hr (2 color)
<b>Drive:</b>	Electro-pneumatic
<b>Printing force:</b>	629N
<b>Vertical pad stroke:</b>	125mm (v4.92")
<b>Air requirements:</b>	5-6 bar (87psi)
<b>Air consumption:</b>	3 cfm @ 80psi
<b>Control system:</b>	12V PCB
<b>Main voltage:</b>	110 - 220V 50-60Hz
<b>Control voltage:</b>	24 VDC
<b>Weight:</b>	80 kg (176 lbs)
<b>Origin:</b>	China

### PRINT SPECS

<b>Plate sizes:</b>	100 x 215mm (Standard) 100 x 200mm (Optional)
<b>Plate thickness:</b>	0.5mm or 10mm
<b>Ink cup size (ID):</b>	<b>Print size (diameter):</b>
90mm (3.54")	80mm (3.14")

\*Specifications are subject to change without prior notification

### DIMENSIONS

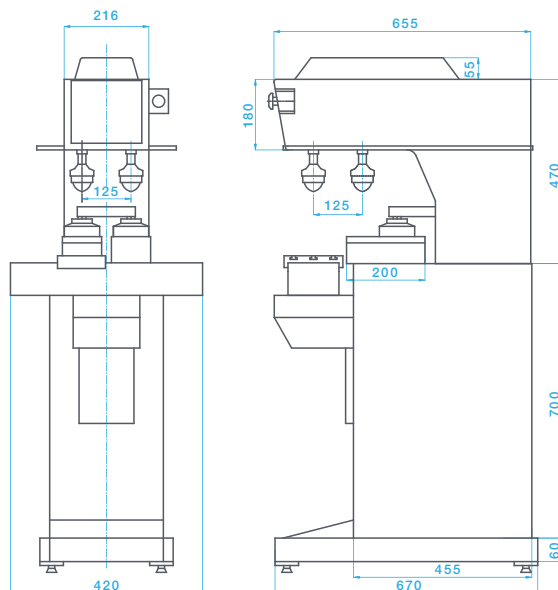

Also available with Pad transport shuttle



Close-up of the touch screen controls



Pneumatic Flow Controls



Pad Stroke Controls

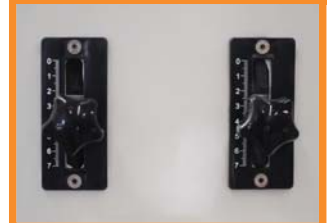

09/26/22



**DECO TECHNOLOGY GROUP, INC.**  
 1040 SEGOVIA CIR  
 PLACENTIA, CA 92870  
 ☎ (800) 300-DECO  
 ☎ (714) 639-3326  
 📠 (714) 639-2261  
 DECOTECHGROUP.COM