

SELECTA-150

MULTI-AXIS CNC LINEAR MOTOR CONTROLLED PAD PRINT MACHINE



solutions in pad printing™

- Variable Information & Personalized (VIP) graphics
- Fully programmable X, Y and Z coordinates
- Interfaced with PC or laptop for data downloads
- Touch screen control with LCD display
- Automatic pad cleaning device
- Automatic ink viscosity control (optional)
- Quick change magnetic ink cup
- Swiss built with world class components



microPrint
Swiss Pad Printing Technology

SELECTA-150

MULTI-AXIS CNC LINEAR MOTOR CONTROLLED PAD PRINT MACHINE

The **microPrint SELECTA-150** is a programmable 3-AXIS CNC Linear Motor controlled pad transfer printer and the **SELECTA-150** introduces a whole new world of possibilities in the pad printing world by allowing you to plot (X/Y/Z) and pad-print **Variable Information & Personalized (VIP) graphics**. Performing much like a laser marking system would, except with the **SELECTA-150** you can print graphics in virtually any color palette. The X, Y and Z coordinates for both image pick-up from the cliché and image placement onto the product, as well as the travel distances for the pads to the cliché and to the part, are all fully programmable. This intelligent and innovative pad printing system is easy to operate and features a "teach mode" for quickly programming the job files and printing parameters. **DECO TECH** is the exclusive North American distributor for **microPrint** and all **microPrint** machines are backed with a limited **3 YEAR FACTORY WARRANTY**.

MACHINE SPECS

Printing capacity:	Up to 2,100 characters/hr
Drive:	Linear/ Pneumatic
Printing force:	710t N Max
Air requirements:	5-6 bar (87 psi)
Air consumption:	.8 L/cycle
Control system:	SPS
Main voltage:	110 - 240 V 50-60Hz
Control voltage:	24 VDC
Weight:	90 kg (198 lbs)
Weight with Stand:	160 kg (353 lbs)
Origin:	Switzerland

PRINT SPECS

Plate sizes with ink cup:	150 x 300mm
Plate size with inkwell:	Special Order Only
Plate thickness:	0.5 or 10mm
Ink cup sizes (diameter):	140mm (3.38")
Print sizes (diameter):	130mm (2.99")

*Specifications are subject to change without prior notification

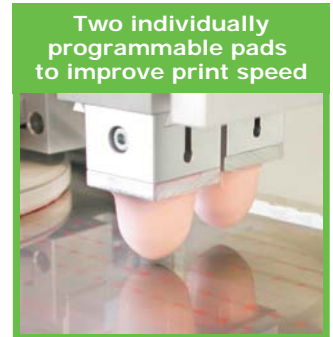

DIMENSIONS

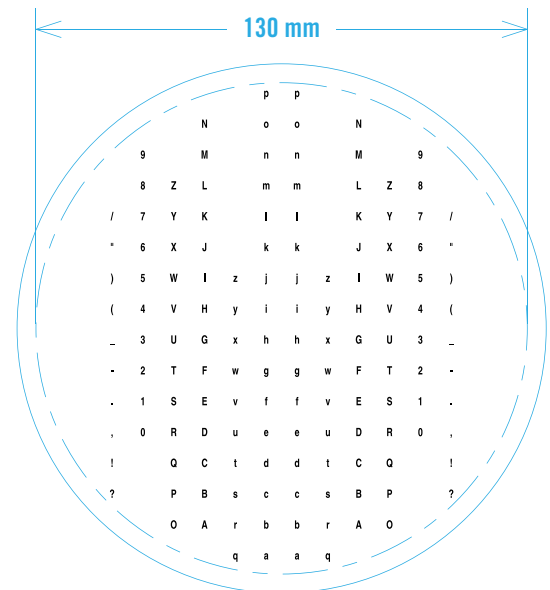
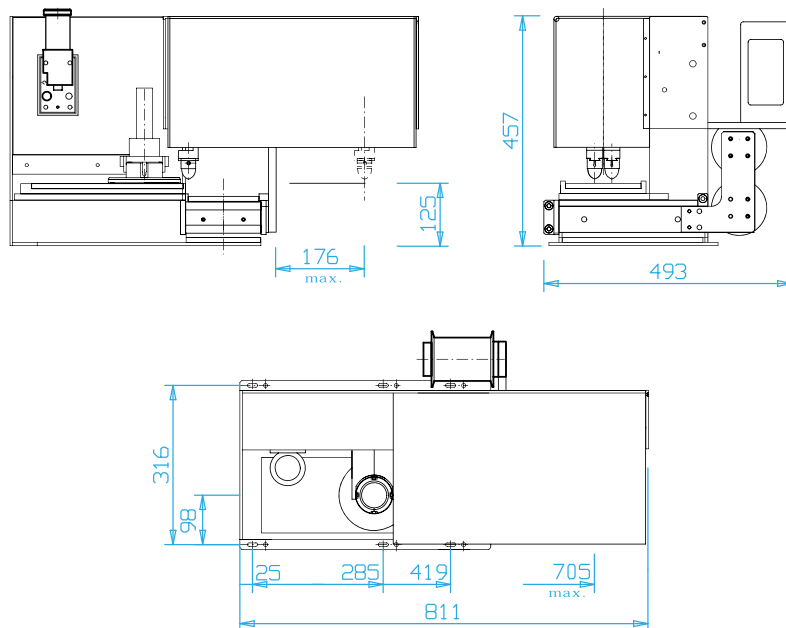

This is an example of a printing plate artwork layout for printing variable data on the SELECTA-150.

© Deco Technology Group, Inc. All rights reserved.



DECO TECHNOLOGY GROUP, INC.
 749 N. MAIN STREET
 ORANGE, CA 92868
 ☎ (800) 300-DECO
 ☎ (714) 639-3326
 ☎ (714) 639-2261
DECOTECHGROUP.COM