

# DT-200-2C

LARGE 1 TO 2 COLOR PAD PRINTING MACHINE



DT-200-2C-PT  
two color model

- Simple to operate using touch panel
- Microprocessor controlled
- SMC pneumatics
- Easily accessible pad stroke adjustments
- X/Y/R/Z work table
- X/Y/R cliché adjustment
- Smooth & quiet machine performance
- 150mm (5.91") diameter ink cup

# DT-200-2C

## LARGE 1 TO 2 COLOR PAD PRINTING MACHINE

The **DT-200-2C** pad printing machine is a large and economical one to two color pad printing system that is both user-friendly and quick to setup. It features a membrane control panel on the front faceplate and the easily accessible pad stroke controls are on the right side of the machine with numerical calibration. The **DT-200-2C** pad printer comes with a solid built welded steel machine base and it has adjustable floor levelers and a height adjustable work table. Inside the machine base you have room to store your pad printing supply items like; inks, thinners, ink cups, mixing cups, stir sticks, etc. This **DT-200-2C** is equipped with two ink cups (see specs below for size) and a X/Y/R adjustable cliché holder for precise alignment of artworks. The clichés can be; photo polymer, thin steel or laser etched varieties and **DECO TECH** provides a full array of consumable supplies, technical support & product training for our **DT SERIES** of pad printing machinery. This **DECO TECH** pad printing machine is backed with a one year warranty against defects in manufacturing.

### MACHINE SPECS

<b>Printing capacity:</b>	Up to 1,400/hr (1 color) Up to 1,200/hr (2 color)
<b>Drive:</b>	Electro-pneumatic
<b>Printing force:</b>	1,559N
<b>Vertical pad stroke:</b>	160mm (6.29")
<b>Air requirements:</b>	5 bars (87psi)
<b>Air consumption:</b>	4-6 Kg/cm <sup>2</sup>
<b>Control system:</b>	12V PCB
<b>Main voltage:</b>	110V 60Hz
<b>Control voltage:</b>	24 VDC
<b>Weight:</b>	170 kg (375 lbs)
<b>Origin:</b>	China

### PRINT SPECS

<b>Plate size:</b>	160 x 300mm (6.30"x11.81")
<b>Plate thickness:</b>	0.5mm or 10mm
<b>Ink cup size (ID):</b>	150mm (5.91")
<b>Print size (diameter):</b>	140mm (5.51")

\*Specifications are subject to change without prior notification

### DIMENSIONS

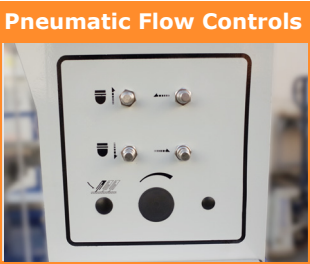
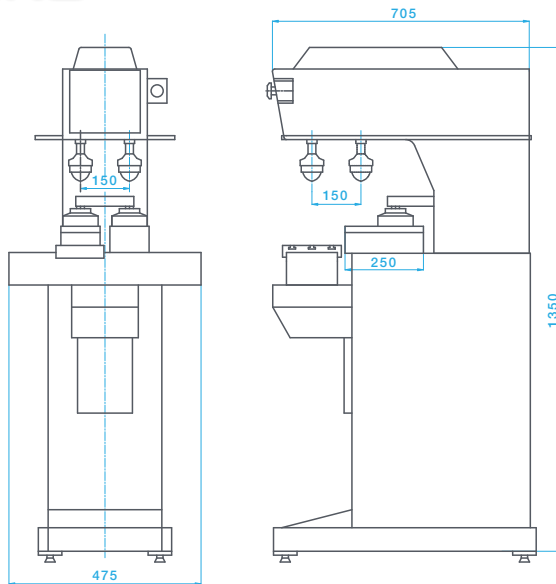

© Deco Technology Group, Inc. All rights reserved.