

# MS-350

MODULAR 1 TO 6 COLOR PAD PRINTING WORKSTATION



Shown with  
optional floor stand

- Fully automatic tape pad cleaning device (optional)
- Fully automatic ink viscosity control (optional)
- Fast cliché change-over without tools
- Touch screen controls with job memory storage
- Quick change magnetic ink cups with X/Y positioning
- Swiss built with world class components

# MS-350

## MODULAR 1 TO 6 COLOR PAD PRINTING WORKSTATION

The **MS-350** pad printing machine is a robust and speedy single or multi-color pad printing machine and its modular design allows you to use many different ink cup sizes in a number of combinations (see specs for details). This solid built and compact pad printer is ideal for printing many injection molded parts, such as medical devices, automotive components, advertising specialty items & many other industrial goods. All **microPrint** machines use only top quality world class components and are built with unparalleled workmanship in Switzerland. **DECO TECH** is the exclusive North American distributor for microPrint and all microPrint machines are backed with a limited **3 YEAR FACTORY WARRANTY**.

### MACHINE SPECS

Printing capacity:	Up to 1,400/hr
Drive:	Pneumatic
Printing force:	1,100 N Max
Air requirements:	5-6 bar (87 psi)
Air consumption:	2.4 l/cycle
Control system:	PLC 24V
Main voltage:	110 - 240 V 50-60Hz
Control voltage:	24 VDC
Weight:	90 kg (198 lbs)
Weight with Stand:	180 kg (397 lbs)
Origin:	Switzerland

### PRINT SPECS

Plate sizes with ink cup:	420 x 250mm Max
Plate size with inkwell:	320 x 120mm Max
Plate thickness:	0.5 or 10mm
<b>Ink cup sizes (diameter):</b>	<b>Print sizes (diameter):</b>
6 x 56mm (2.20")	6 x 50mm (1.96")
5 x 70mm (2.75")	5 x 60mm (2.36")
4 x 86mm (3.38")	4 x 76mm (2.99")
3 x 120mm (4.72")	3 x 110mm (4.33")

\*Specifications are subject to change without prior notification

### DIMENSIONS

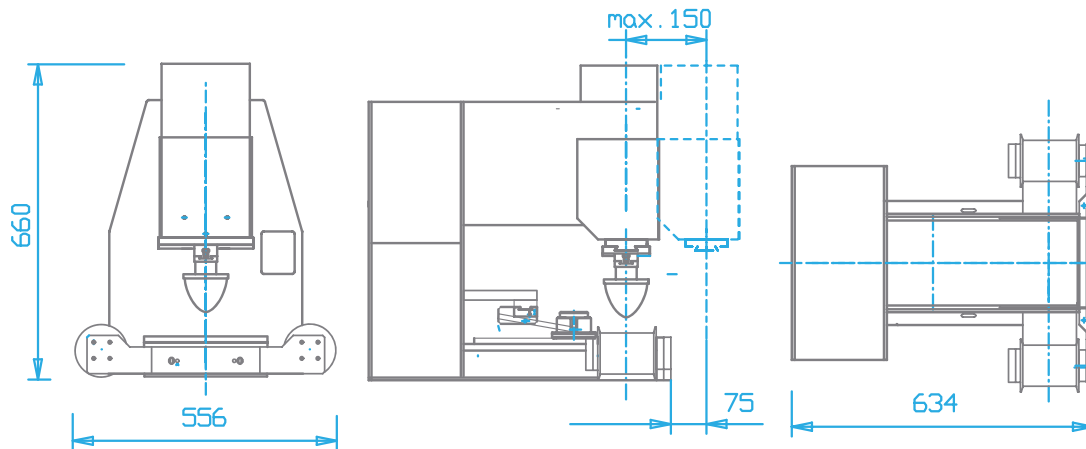

MS-350 shown in table top configuration



Easy to operate touch screen controls



X/Y/R plate adjustment & quick change ink cups



MS-350 also available with covered inkwell



Check out our complete line of pad printing supplies including Printcolor brand inks.

© Deco Technology Group, Inc. All rights reserved.

**DECO TECHNOLOGY GROUP, INC.**

1040 SEGOVIA CIR

PLACENTIA, CA 92870

(800) 300-DECO

(714) 639-3326

(714) 639-2261

DECOTECHGROUP.COM

